

On load-bearing floors with LK CombiBoard EPS 14/18/30/50/70

DESIGN

- LK Underfloor Heating system with LK CombiBoard EPS for installation on load-bearing floor constructions.
- The system consists of insulation boards of EPS class S300, equipped with a laminated heat distribution layer for optimal heat distribution.
- LK CombiBoard EPS offers high thermal insulation and excellent performance properties for both short- and long-term loads.
- The grooved EPS underfloor heating boards feature integrated turning grooves within each board.
- LK CombiBoard EPS Feed is intended for use when underfloor heating pipes need to be installed with narrow pipe spacing between the heating manifold and the room. Since LK CombiBoard EPS Feed is not equipped with a laminated heat distribution layer, heat dispersion from the supply section is reduced. The board is made of EPS, class S300.



LK CombiBoard EPS 14/18/30/50/70, c/c 200 mm.



LK CombiBoard EPS 30/50/70, c/c 100 mm.

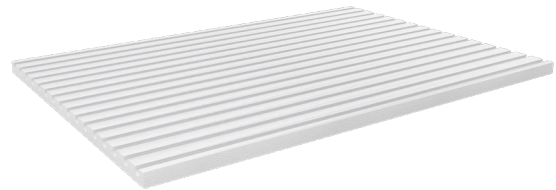

LK CombiBoard EPS 30/50/70 Feed, c/c 50 mm.

Product summary

Product name & pipe spacing	Pipe.dim.	Article.No.
LK CB EPS 14 c/c 160 mm	12 mm	241 04 63
LK CB EPS 18 c/c 200 mm	16 mm	241 04 64
<hr/>		
LK CB EPS 30 Feed c/c 50 mm	16 mm	241 05 00
LK CB EPS 30 c/c 100 mm	16 mm	241 04 97
LK CB EPS 30 c/c 200 mm	16 mm	241 04 65
<hr/>		
LK CB EPS 50 Feed c/c 50 mm	16 mm	241 05 01
LK CB EPS 50 c/c 100 mm	16 mm	241 04 98
LK CB EPS 50 c/c 200 mm	16 mm	241 04 66
<hr/>		
LK CB EPS 70 Feed c/c 50 mm	16 mm	241 05 02
LK CB EPS 70 c/c 100 mm	16 mm	241 04 99
LK CB EPS 70 c/c 200 mm	16 mm	241 04 67
<hr/>		
* CB = CombiBoard		

TABLE OF CONTENTS	
Design	1
Requirements	2
Laying LK CombiBoard EPS boards	3
Laying method – procedure	4
LK Manifold	9
Laying the pipes	9
Installation of flooring material	9
Ceramic flooring	10
Other types of flooring material	16
Environment / Recycling	21
Miscellaneous	21
Technical data	22
Dimension drawings	23



ATTENTION!

This installation guide has been developed to suit Scandinavian construction methods and climate conditions. It is essential that distributors in each region ensure that both the products and installation methods comply with all applicable local building regulations and standards. The responsibility for proper installation in accordance with local regulations rests entirely with the distributor and/or installer.

Ensure that all necessary tools and materials are available before starting installation.

Read the entire installation guide before starting any on-site work.





REQUIREMENTS

The requirements for a properly functioning underfloor heating system are requires a weather-compensated control system for the supply temperature and well-implemented and documented adjustment of the primary and loop flows.

LK CombiBoard EPS must only be laid on load-bearing floor constructions. Load-bearing floor constructions refers to concrete or floor-grade chipboard fixed to joists spaced at a maximum of c/c 600 mm. LK CombiBoard EPS boards must not be laid over any other floor insulation, as multiple layers of insulation cause poor floor resilience. In general, the installation shall follow applicable local building standards and any specific instructions provided by the responsible contractor or quality manager. The Swedish AMA Hus standard may be used as a reference where relevant.

Uninsulated concrete floor constructions or cellar floors



RISK! Heat loss and moisture transfer

Uninsulated concrete floor construction or cellar floors may cause heat loss and moisture transfer. The construction should be damp-proofed. If you are unsure, contact a damp consultant or other expert for advice.

When an underfloor heating system is to be installed on non-insulated concrete slabs or cellar floors, there is an increased risk of heat loss to the ground. In addition to the increased cost of heating, this can also result in an increased risk of moisture transfer to the space from the floor and cellar walls. There are various ways to damp-proof the floor construction. One way is to incorporate a layer that forms an air gap. Another is to choose a floorboard with extra insulation. If there is a risk of additional moisture, contact an expert for advice.

Definitions of wet Rooms and Dry Rooms

In this manual, the following definitions apply:

- Wet rooms are rooms where floors and/or walls are regularly exposed to water or moisture. This includes bathrooms, shower rooms, laundry rooms with floor drains, and other spaces equipped



with plumbing fixtures and floor drainage. These areas must be protected with waterproofing layers in accordance with local or national building codes.

- Dry rooms are rooms that are not normally exposed to water or high humidity, such as living rooms, bedrooms, hallways, offices, and similar areas.

LAYING LK COMBIBOARD EPS BOARDS



RISK! Reduced bearing capacity

As a large number of underfloor heating circuits will be connected to the manifold, there is a risk of the bearing capacity being inadequate for the overlying floor. See illustration below. In such cases, it may be best to remove part of the LK CombiBoard EPS and fill in the gap with levelling compound. The risk is the same where a large number of underfloor heating circuits are forced together into a small space, e.g. when they pass between rooms.

RISK! Sharp edges! Use protective gloves

The laminated heat distribution layer on LK CombiBoard EPS boards has sharp edges. Use protective gloves when handling LK CombiBoard EPS boards.

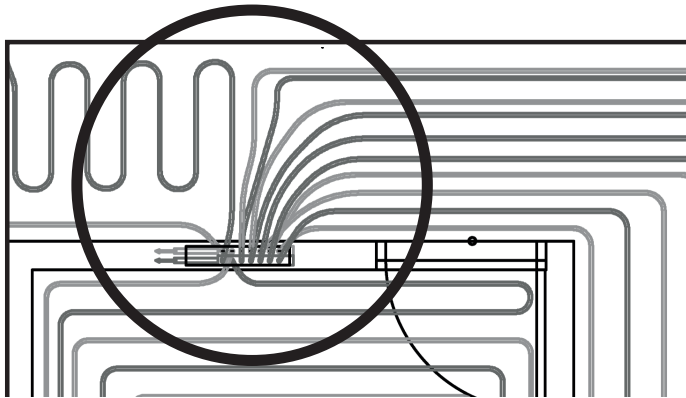

NOTE! The flatness of the sub-floor

Before installing LK CombiBoard EPS ensure that the sub-floor is level. As a guideline, surface flatness should not deviate more than ± 3 mm over a distance of 2 metres and ± 1.2 mm over a distance of 0.25 metres. The sub-floor must be vacuum-cleaned to remove all dirt and dust prior to installation. Always comply with applicable local or national building codes and flooring regulations.

NOTE! Ceramic flooring

If laying ceramic flooring, the LK CombiBoard EPS boards must be glued to the sub-floor, see "*Installation, primer and adhesive in dry rooms – Table 1.*" on page 12 and "*Installation, primer and adhesive in wet rooms – Table 2.*" on page <?> for the glue products to be used.



RECOMMENDATION! Tape pipe turns

LK recommends taping all pipe turns with LK Aluminium Tape during pipe installation. Any protruding pipes should also be fully covered using LK Aluminium Tape.

Attachment to the sub-floor

LK CombiBoard EPS must be attached to the sub-floor using one of the methods indicated below.

- **Adhesive bonding:** Adhesive, floor fix or adhesive compound may be used depending on the room type and surface.
- **Mechanical fastening with screws:** LK CombiBoard EPS boards can be screwed to the subfloor, particularly when chipboard or similar materials are used.
- **When using screws:**
 - Choose fasteners suitable for the subfloor material.
 - Choose screws with a large head or washers to ensure proper load distribution.
 - Screw heads should be countersunk to maintain surface flatness.
- **Reusing the system** or individual boards is possible if the boards are secured with screws.

LAYING METHOD – PROCEDURE



ATTENTION!
Read through this section before starting work.



TIP!
Begin the installation in the room furthest from the underfloor heating manifold. Boards that require size adjustment should be cut using a circular saw, plunge saw, or utility knife.

Step 1 – Test installation of LK CombiBoard EPS boards

1. Begin by laying out the LK CombiBoard EPS boards without applying any adhesive or mechanical fastening. Start at the short side of the room where only pipe turns will be placed. Begin the installation from the short side of the room equipped only with pipe return loops. If the pipes are to be installed with 100 mm centres, it is important to note that the CombiBoard with 100 mm centres has return grooves for 200 mm centres at one end of the board and pear-shaped return grooves adapted for 100 mm centres at the other end.

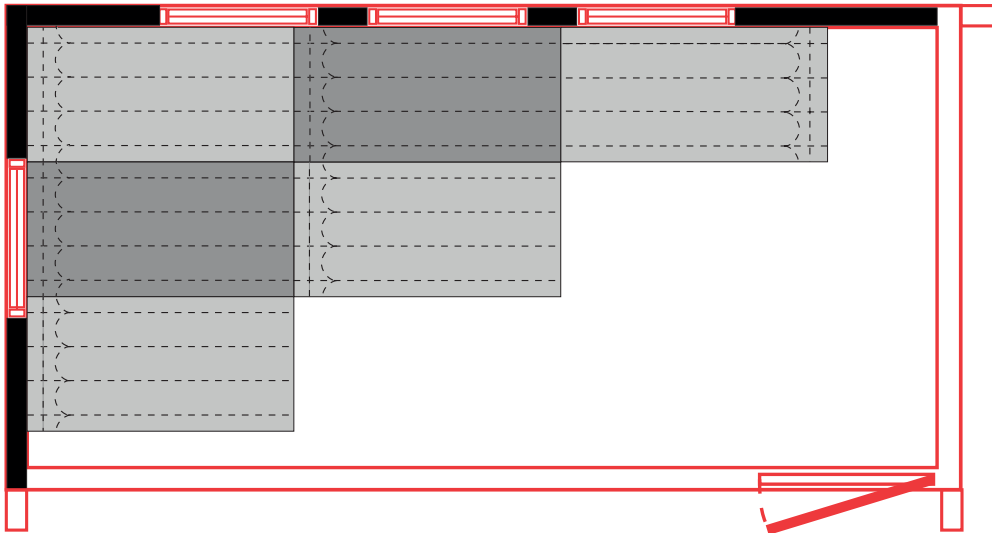

2. Continue placing the boards, covering the full width of the room to verify fit and layout before final installation.

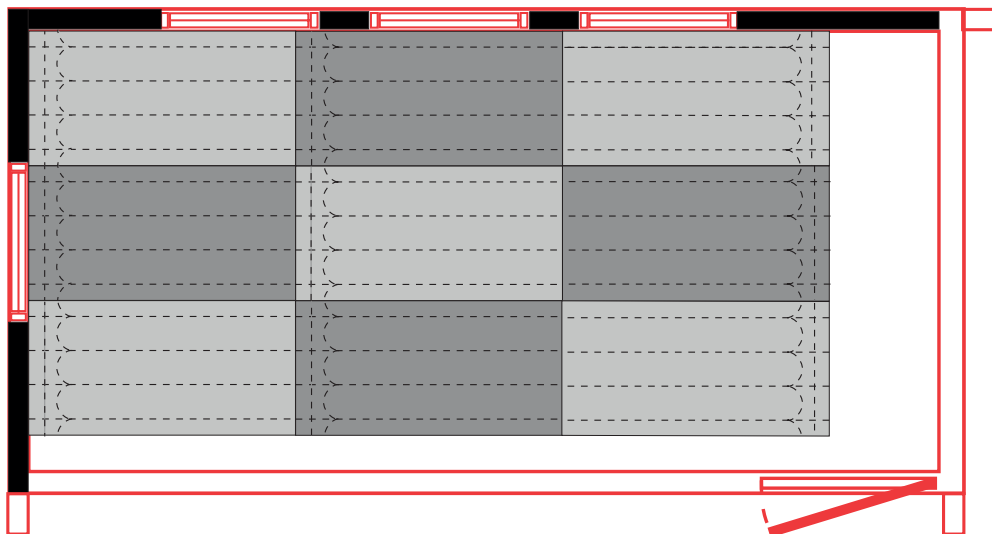

- Continue by filling the remaining floor area with cut boards. Pay attention in areas where supply pipe runs are to be installed. Use appropriate cutting tools to ensure clean and accurate grooves. Note! LK CombiBoard EPS boards can be cut both lengthwise and widthwise to create suitable grooves for the supply pipe, particularly where pipe turns are needed.

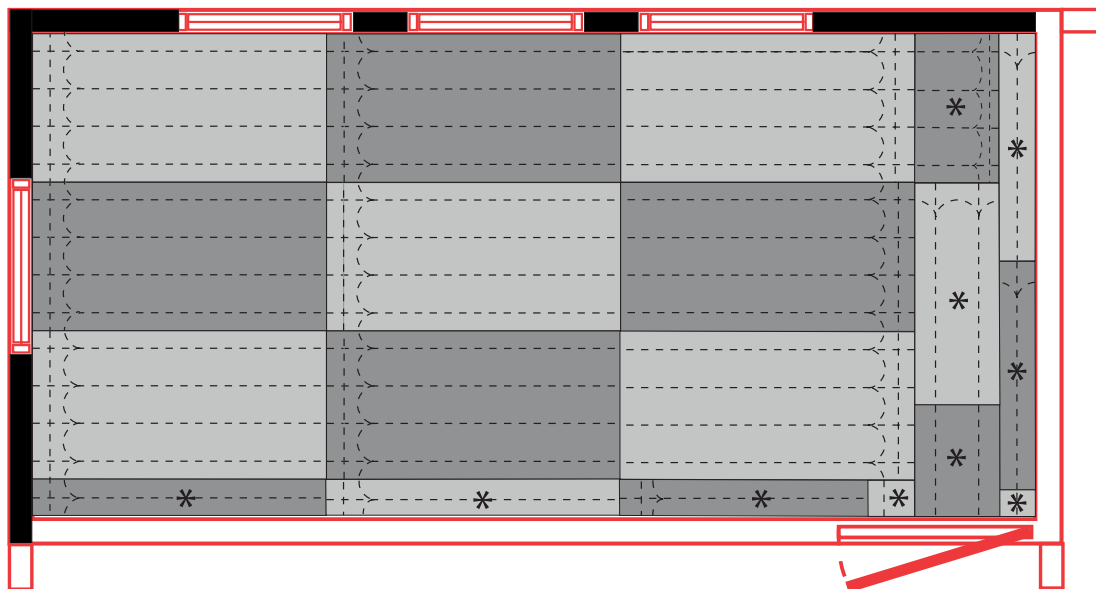

Example image. The image shows what a test layout may look like. * LK CombiBoard EPS boards that have been cut.

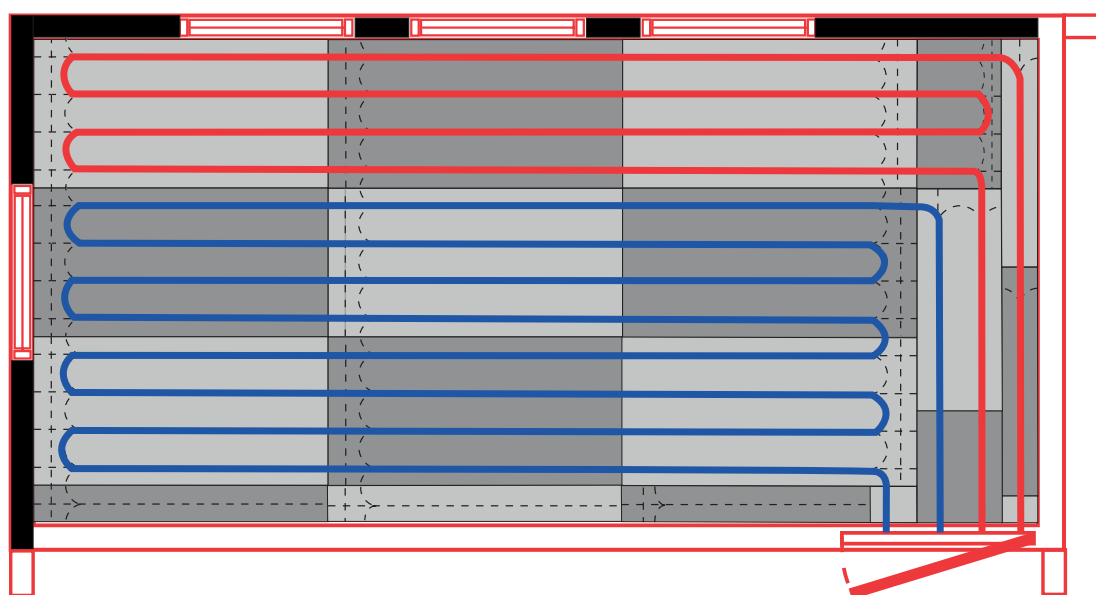

Example image: Shows the test layout with a pipe system with two loops placed in position.

Step 2 – Installing LK CombiBoard EPS boards

- Once all LK CombiBoard EPS boards have been properly adjusted and positioned during the test layout, remove them and select the appropriate installation method. Proceed with one of the methods described in steps 3a, 3b, 3c and 3d on the next page.
- After selecting the method, lay the boards again in their final positions.
- Work systematically from the short side of the room toward the connection point, i.e. where the supply and return pipes enter the room.



Attachment methods

**NOTE! Deviations between recommendations**

The information in this section provides general recommendations. Always follow the specific instructions and guidelines provided by the manufacturer of the adhesive or floorfix product selected, as these may vary depending on the type of material and floor structure.

Step 3a – Gluing with cement-based tile adhesive or using the double gluing method with recommended adhesive

**TIP! Floor adhesive**

If the surface layer consists of ceramic tiles, the installation method using flexible tile adhesive or standard tile adhesive is commonly used. When using cement-based tile adhesive, the LK CombiBoard EPS boards must be installed before the adhesive begins to set. Once the boards have been placed, avoid applying any additional load until the adhesive has fully dried.

See *"Installation, primer and adhesive in dry rooms – Table 1."* on page 12 and *"Installation, primer and adhesive in wet rooms – Table 2."* on page <?> for recommended floor adhesive products. Always refer to the adhesive supplier's instructions for correct installation.

1. Apply the cement-based tile adhesive using a 3-6 mm notched trowel or use the double gluing method (apply a smooth layer to the board and a ridged layer to the subfloor).
2. Lay each board in place, adjust as needed, and press down firmly. Any excess adhesive that rises through the joints must be removed before it hardens.
3. Walk gently on the boards to ensure full bonding with the subfloor.
4. Check for proper adhesive coverage: when gluing with cement-based tile adhesive, it is important that the adhesive spreads properly. Carry out a random check by lifting one of the boards and verify that the adhesive has spread uniformly.
5. Strive for 100% coverage beneath each board — no air pockets, ridges, or unbonded areas should remain.

Step 3b – Gluing with water-based floor adhesive

**TIP! Floor adhesive**

If the LK CombiBoard EPS boards "slide" on the adhesive during installation, they have been laid too early. Allow the adhesive to become tacky before proceeding. If the adhesive has dried too much, apply a fresh layer over the existing one — otherwise, adhesion may be compromised.

See *"Installation, primer and adhesive in dry rooms – Table 1."* on page 12 and *"Installation, primer and adhesive in wet rooms – Table 2."* on page <?> for recommended adhesives products. Always refer to the relevant supplier's instructions for correct installation. Water-based floor adhesive should be applied using a suitable adhesive spreader. Consumption: 3-5m²/litre. The humidity in the concrete subfloor should never be greater than 85 %.

1. Work in sections to avoid stepping into wet adhesive. It is recommended to start at the farthest point in the room.
2. Allow the adhesive to dry until tacky to ensure a stronger bond when the LK CombiBoard EPS boards are laid. This typically takes between 10 to 30 minutes depending on the adhesive type,, subfloor material and room temperature.
3. Gently walk on the LK CombiBoard EPS boards to ensure full bonding with the subfloor.

Step 3c – Simplified adhesive method using Bostik PU 800

**NOTE!**

The simplified adhesive method shall only be used in dry areas.

Private individuals: Must ensure that protective gloves are included in the product packaging, and used in accordance with the safety recommendations stated in the Safety Data Sheet (SDS), particularly regarding personal protective equipment (PPE) and safe handling procedures.

Contractors working for end customers: Contractors must complete the designated training and review the installations instructions provided by Bostik.

Professional users/tradespeople: professional users must complete the required training and thoroughly review Bostik's installation instructions before using the product.



For detailed instructions, visit the Bostik website to download the relevant installation guides. Always read all instructions provided by Bostik carefully before using the product. Further information can also be found on LK’s product page for LK CombiBoard EPS.

Step 3d – Installation to the subfloor using screws



NOTE! Screws and ceramic tiles

Attaching LK CombiBoard EPS boards to the subfloor using **screws is not suitable when ceramic tiles are used as the final floor covering.**

NOTE! LK CombiBoard EPS 30/50/70 and LK CombiBoard EPS 30/50/70 Feed

The Feed EPS board **must be fastened with screws only in areas where the board retains its full thickness.** Do not screw into the pipe grooves.

1. Select appropriate screws for the subfloor material (e.g. mounting screws. length of screws should be less than the total thickness of the EPS board and subfloor). Screws with large heads or washers are recommended to ensure even load distribution. Use a minimum of five screws, placed as shown by positions 1 to 5. If needed, add additional screws at positions 6 to 9 according to the illustration.

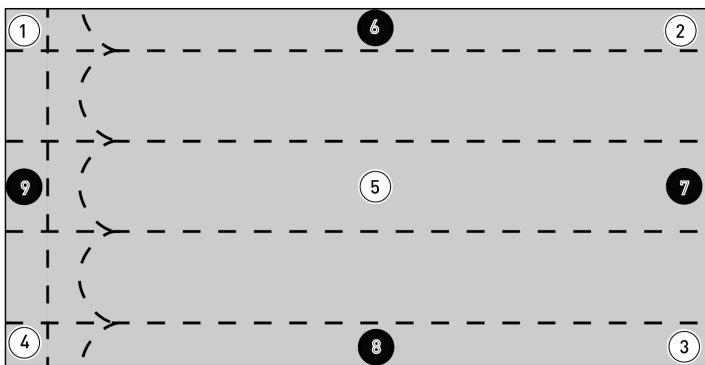

2. Position the LK CombiBoard EPS board in place and make any necessary adjustments.
3. Attach the LK CombiBoard EPS board to the subfloor. Ensure that the screw heads are fully countersunk into the board to avoid any risk of contact with the final floor covering. Check the countersinking of the screw heads by running a try square or ruler across the surface to confirm that no screw heads protrude.

LK CombiBoard EPS	The recommended max. screw length
LK CB EPS 14	25 mm
LK CB EPS 18	32 mm
LK CB EPS 30 Feed	45 mm
LK CB EPS 30	45 mm
LK CB EPS 50 Feed	65 mm
LK CB EPS 50	65 mm
LK CB EPS 70 Feed	85 mm
LK CB EPS 70	85 mm
* CB = CombiBoard	



NOTE! Screw lengths

The table provides guidance on suitable screw lengths. Adjust the screw length according to the conditions of the project, such as the type of subfloor.



Step 4 – Supplement with new pipe grooves



NOTE! Boards

Before cutting or milling new pipe grooves, ensure that the adhesive has fully cured and that the LK CombiBoard EPS boards are firmly bonded to the subfloor.



Pipe grooves

Ensure that both the supply and return pipes for the underfloor heating system have designated pipe grooves. If necessary, a new groove can be cut locally to complete the pipe circuit, particularly where multiple pipes converge at the manifold.

1. Mark the intended pipe groove path using a pen pen (for example, a soft-tipped marking pen). Ensure that the pipe bend is not too tight; the minimum bend radius for 16 mm pipes is 90 mm. Contact your pipe supplier for more detailed information if required.
2. Cut the new pipe groove using a plunge router. Select a router cutter dimension appropriate for the pipe diameter.

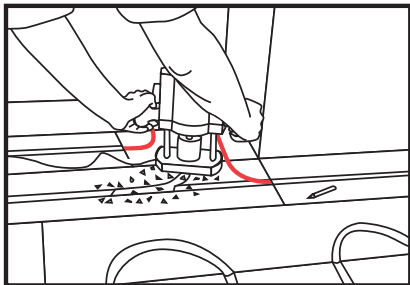

3. Fold aluminium tape neatly into the milled groove before installing the pipe.

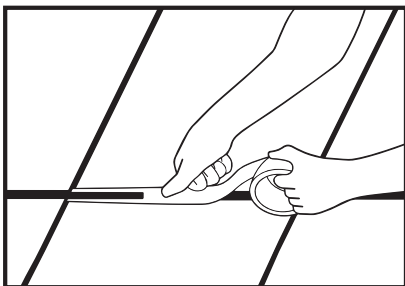

4. Secure the pipe in place by taping it down using aluminium tape.

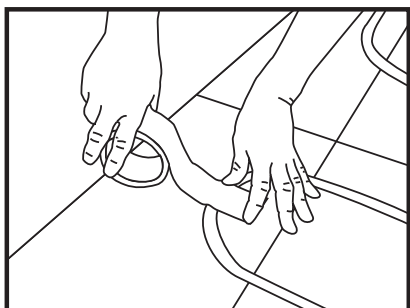

LK MANIFOLD



ATTENTION!

Read through the manifold's assembly instructions before starting to install it. See www.lksystems.se/en/. The manifold is assembled in the designated place as per the drawing.

LAYING THE PIPES

The pipe layout must follow the system drawing. Check that all planned turning grooves are properly prepared. If needed, cut the foil with a knife and fold it down into the turning grooves.

1. Before laying the pipes, make sure all grooves and surfaces are free of debris. Vacuum clean if necessary.
2. Number and name the loops according to the system drawing.
3. Cut the pipe using pipe cutters designed for underfloor heating pipes.
4. Press the pipes into the grooves. You may use your foot for assistance where needed.
5. Use aluminium tape over pipe turns and at all points where the pipes protrude from LK CombiBoard EPS board.
6. Follow the flow direction marked on the drawing. The supply pipe should always be routed along the outer walls.

INSTALLATION OF FLOORING MATERIAL



RISK! Loose LK CombiBoard EPS boards

Ensure that all LK CombiBoard EPS boards are firmly secured to the sub-floor. Any loose boards must be properly fixed before installing ceramic tiles or floating flooring.

RISK! Insufficient tile adhesive coverage

Perform random checks by lifting a ceramic tile to verify 100% adhesive coverage.



NOTE! Deviations between recommendations

The information in this section provides general recommendations. Always follow the specific instructions provided by the adhesive or floorfix product manufacturer, as requirements may vary depending on the floor type and construction.

Once the underfloor heating system has been installed and successfully pressure-tested, the surface flooring can be laid. The underfloor heating system must be turned off during this process. This is especially important when installing ceramic tiles, as elevated temperatures can affect the drying time and long-term performance of the adhesive and grout.

Before laying the surface layer, ensure that:

- The LK CombiBoard EPS boards are securely bonded to the sub-floor.
- The installation is firm (not springy).
- No creaking or movement occurs between the boards and the subfloor.
- All pipes are correctly positioned within their pipe grooves.



CERAMIC FLOORING

The methods of laying tiles, system solutions and requirements differ depending on the type of room in which the underfloor heating system has been installed. A major difference is between dry rooms and wet rooms:

- **In dry rooms**, ceramic tiles may be installed directly on top of the underfloor heating system.
- **In wet rooms**, building regulations require a layer of levelling compound (screed/filler) with embedded mesh reinforcement above the system before tiling. Consult a qualified specialist. Also refer to, for example, the instructions provided by the levelling compound manufacturer.

Construction principle - Ceramic flooring in dry rooms

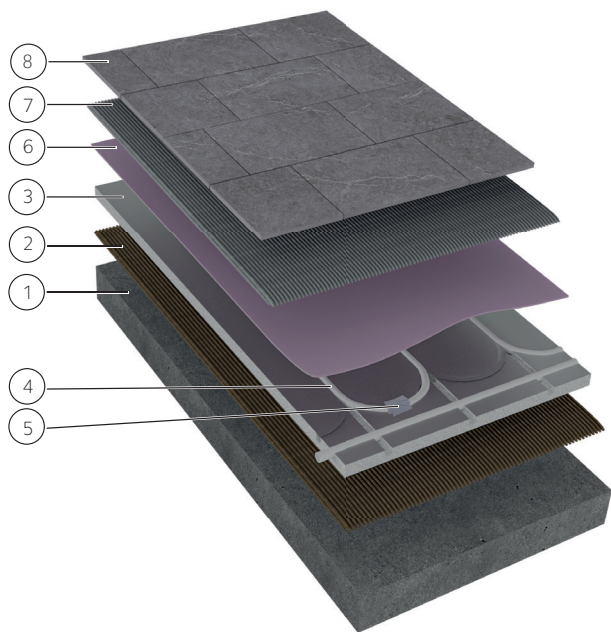

1. Concrete.
2. Recommended adhesive/ adhesive-compound or glue from the supplier.
3. LK CombiBoard EPS.
4. LK Underfloor Heating Pipe.
5. LK Aluminium Tape.
6. The supplier's recommended special primer or as per the supplier's recommendations.
7. Adhesive/Adhesive-compound.
8. Ceramic tiles.

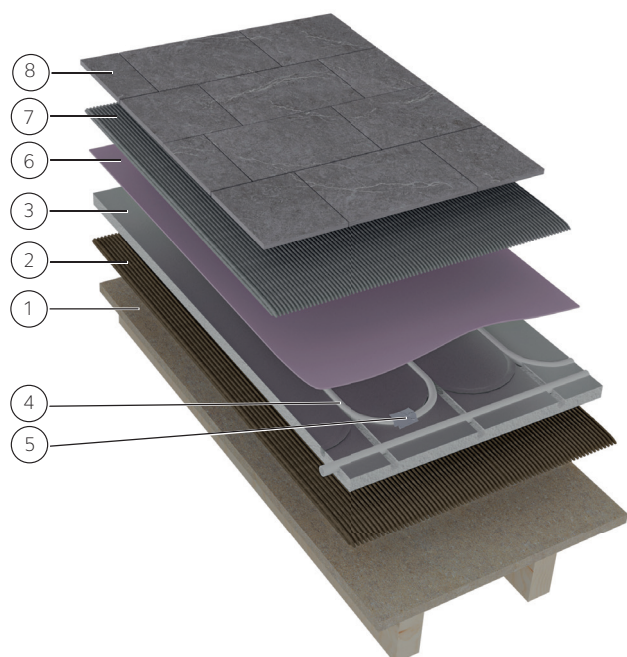

1. Wooden joists with floor-grade chipboard.
2. Recommended glue as per the supplier's instructions.
3. LK CombiBoard EPS.
4. LK Underfloor Heating Pipe
5. LK Aluminium Tape.
6. The supplier's recommended special primer or as per the supplier's recommendations.
7. Adhesive/Adhesive -compound.
8. Ceramic tiles.



Requirements (dry rooms)

In **dry rooms**, ceramic tiles can be installed directly on top of the underfloor heating system, provided that the following conditions are met:

- The floor structure is stable.
- There is no springiness in the construction. Any movement in the floor structure may eventually cause cracks in the joints or loosen the tiles.

The primer should be applied undiluted, unless otherwise indicated in the supplier's instructions. For products, see "*Installation, primer and adhesive in dry rooms – Table 1.*" on page 12. Not all primers are compatible with the laminated (aluminium) heat distribution surface. Always consult the primer supplier if in doubt.

The size of the ceramic tiles

Ceramic tiles, in combination with adhesive compound, help distribute point loads across the surface.

- The ceramic tiles *must* be no smaller than 150x150 mm.
- For smaller formats or mosaic tiles, either, apply a load-distributing board or, add a layer of fibre-reinforced levelling compound on top of the heating system.
- Levelling compound may also be applied on top of LK CombiBoard EPS to strengthen the subfloor.

Installing ceramic tiles



NOTE!

For this type of construction, LK CombiBoard EPS must be bonded to the subfloor. The surface of the LK CombiBoard EPS boards must be cleaned with methylated spirits to remove any dust, oil, grease, etc. from the surface. Do not use any other solvents, as these may damage the cellular plastic.



NOTE! LK CombiBoard EPS 30/50/70 and EPS 30/50/70 Feed

The number of empty, i.e. unused, pipe grooves should be kept to a minimum. Any unused pipe grooves must be filled with tile adhesive or levelling compound.

1. Clean the surface of the LK CombiBoard EPS boards.
2. Apply the primer in accordance with the supplier's instructions. Ensure that it is spread evenly across the entire surface without forming puddles. A uniform application and correct quantity are essential for proper adhesion.
3. Allow the primer to dry according to the instructions.
4. Mix the adhesive compound according to the manufacturer's instructions.
5. Use a suitable notched trowel, selected based on the tile size, surface structure, and adhesive type.
6. Perform a test-lay:
 - The adhesive should form stable ridges — not flatten out (too wet) or forming clumps (too dry).
 - Press the tile into position with slight displacement.
 - Lift and inspect for coverage: the back of the tile must have 100% adhesive contact.



Installation, primer and adhesive in dry rooms – Table 1.

This table lists the laying methods and products that have been tested and are recommended for the Scandinavian markets. Always follow the instructions provided by your local supplier for correct installation. For additional guidance or questions, contact your local supplier directly.

Supplier	Installing LK CombiBoard EPS boards	Primer on the laminated heat distribution layer (aluminium)	Tiling
Alfix A/S	Alfix Ready Flex	Alfix UniversalPrimer	Alfix ProFix/ProFix Plus or Alfix QuickFix Premium
Bostik AB	On chipboard or concrete below 85 % RH: STIX A500 Combi, Bostik STIX A511 Combi Air or STIX A800 Premium. Concrete sub-floor: Bostik 8070 Light LT (double glued) or Bostik 8040 Flow LT.	Bostik GRIP A936 Xpress	Bostik 8070 Light LT or Bostik 8040 Flow LT
Kiilto AB	Kiilto Floorfix DF together with Kiilto Pro Fixbinder.	Kiilto Fix Pro Primer	Kiilto Floorfix DF, Kiilto Highflex S2 DF, Kiilto Superfix DF, Kiilto Pro Lightfix.
LIP	Mount the boards using LIP XXL Large Format Adhesive.	LIP Supergrund	Ceramics are installed using LIP Multi Tile Adhesive, LIP XXL Large Format Adhesive, or LIP Rapid Adhesive. Natural stone is installed using LIP Natural Stone Adhesive or LIP Rapid Adhesive. In all cases, the adhesive must be reinforced with a mixture of LIP Multibinder and water, pre-mixed in equal parts. This mixture replaces the specified amount of water.
PCI	Installation on concrete: Mount the boards with PCI Flex-mortar S1 Flott. Installation on wooden beams: Mount the boards with PCI Flex-mortar S1 Flott.	Installation on concrete: Prime with PCI Gisogrund 303. Installation on wooden beams: Prime with PCI Gisogrund 303. Putty min. 15mm with PCI Periplan CF35 / PCI FT Plan Pro, use ROT mesh or equivalent, use PCI Peci-tape Silent (Edge tape).	Installation on concrete: Tiling can be done with PCI Flexmörtel S1 Flott / PCI Flexmörtel S1 / PCI Flexmörtel S2, PCI Nanorapid Tiling with natural stone is carried out with PCI Carraflex. Installation on wooden beams: Tiling can be done with PCI Flexmörtel S1 Flott, PCI Flexmörtel S1, PCI FT Extra, PCI Nanolight, PCI Nanorapid. Tiling with natural stone is carried out with PCI Carraflex.
Mapei AB	Dry areas, level sub-floors: Mapei Ultrabond Eco V4SP Evo Cement-based sub-floors: Ultralite S2 Flex Zero or Ultralite S2 Flex Quick Zero	EcoPrim T or EcoPrim Grip Plus	Ultralite S2 Flex Zero or Ultralite S2 Flex Quick Zero
SCHÖNOX	Installation on concrete: Mount the boards with Schönox FS. Installation on wooden beams: Mount the boards with Schönox FS.	Installation on concrete: Prime the discs with Shönox SHP. Installation on wooden beams: Prime the boards with Schönox SHP. Putty with Schönox SP and use Schönox PZG (reinforcing mesh) with Schönox RS 50 (Edge strip). my. 15 mm.	Installation on concrete: Perform tiling with Shönox Q12 Installation on wooden beams: Tiling can be done with Schönox Q6, Q6W, Q8, Q9W, Q12, TT S8 and TT S8 Rapid.
SikaCeram	Mount the boards with Casco Husfix Rapid.	Prime with SikaFloor-02 Primer. Putty with SikaCeram-450 Thermo Level and with a root net. my. 20mm.	Tiling can be done with SikaCeram-260 StarFlex and 275 Marble & Stone.



Ceramic flooring in wet rooms



ATTENTION!

The installation of ceramic tiles in wet rooms must comply with the relevant local or national building codes and waterproofing standards. This includes for example structural rigidity, moisture barrier application, junction details, and floor gradients toward drains. The Swedish industry guidelines are available for reference at www.bkr.se.

Construction principle - wet rooms

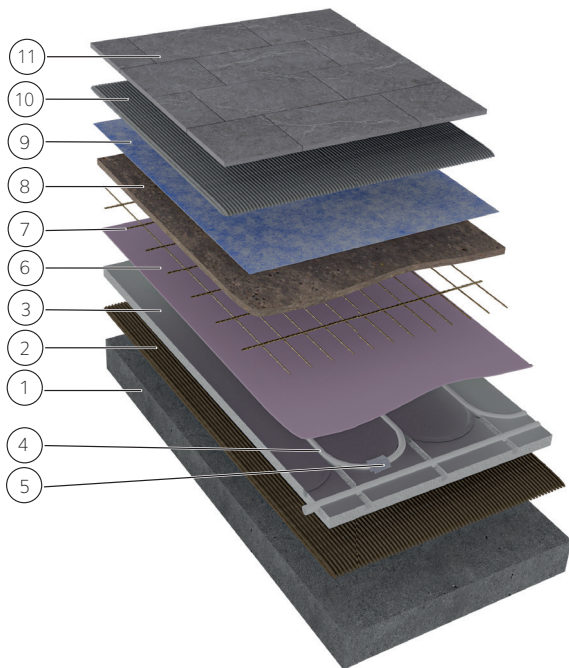

1. Concrete.
2. Recommended adhesive/ adhesive-compound or glue from the supplier.
3. LK CombiBoard EPS.
4. LK underfloor heating pipe.
5. LK Aluminium Tape.
6. The supplier's recommended special primer or as per the supplier's recommendations.
7. Reinforcement.
8. Drainage slope.
9. Moisture barrier.
10. Adhesive-compound
11. Ceramic tiles.

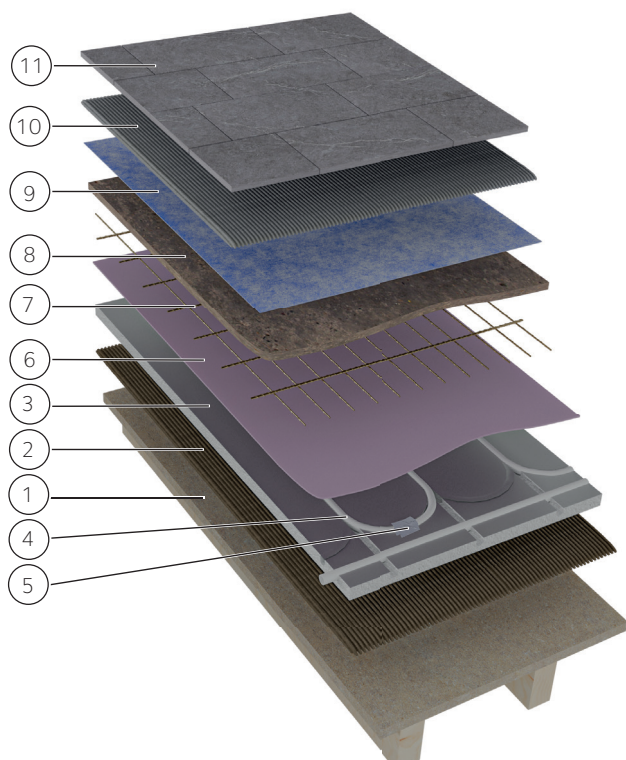

1. Wooden joists with floor-grade chipboard.
2. Recommended glue as per the supplier's instructions.
3. LK CombiBoard EPS.
4. LK underfloor heating pipe.
5. LK Aluminium Tape.
6. The supplier's recommended special primer or as per the supplier's recommendations.
7. Reinforcement.
8. Drainage slope.
9. Moisture barrier.
10. Adhesive-compound
11. Ceramic tiles.



Checklist

**NOTE! Requirements for levelling compound**

When LK CombiBoard EPS boards are installed in wet rooms with ceramic tile finishes, **a layer of levelling compound must be applied over the underfloor heating system**. This layer must then be covered with an approved moisture barrier suitable for floor applications.

**NOTE! Adhesive requirements**

LK CombiBoard EPS must always be adhered to the subfloor using a suitable adhesive in wet room applications.

- Check that the floor structure complies with the relevant local or national building codes (BBV).
- Install the underfloor heating system (LK CombiBoard EPS boards and pipes, etc.).
- Carry out a pressure and leak test of the underfloor heating system. The installation must comply with applicable local or national standards for waterborne heating systems, including waterproofing and testing requirements. As a reference, the Swedish industry guidelines for safe water installations are available at www.sakervatten.se. LK's *assembly instructions for PE-X, PAL, and PE-RT pipes* includes guidelines for a pressure and leakage test of the underfloor heating system.
- For the floor drain, leave at least 150 mm around the drain area uncovered by LK CombiBoard EPS. Apply floor levelling compound in such a way that a hard edge forms at the junction with the floor drain.
- Ensure that the floor levelling compound does not bond to walls or fixed objects, such as pedestals. This can be achieved by using an edge strip made from foamed plastic or equivalent. As all concrete based products shrink during curing, it is important that the underfloor heating system has room to move away from the wall. Failure to allow this may result in cracking and poor adhesion, or detachment of the LK CombiBoard EPS. Make sure that the levelling compound supplier's requirements for room and surface temperatures are met.
- Clean the LK CombiBoard EPS boards with methylated spirits (do not use other solvents, as these may damage the cellular plastic) and apply undiluted primer.
- Allow the primer to dry. **Check that the primer spreads evenly and forms a complete film**, as not all primers adhere properly to the laminated (aluminium) heat distribution layer. See "*Installation, primer and adhesive in wet rooms – Table 2.*" on page 15.
- **For wooden subfloors, regardless of joist spacing (up to a maximum of 600 mm), reinforcement of flexural stiffness and moisture protection must be applied before installing ceramic tiles.** Reinforcement can be done with screed min. 12 mm at floor drain. Reinforcement can be done using a screed layer with a minimum thickness of 12 mm at the floor drain. The reinforcement should be placed at the lower edge of the screed using spot-welded steel mesh or equivalent, in accordance with the supplier's instructions.
- Lay the mesh reinforcement on top of the underfloor heating system. Any mesh joints must overlap.
- Apply the levelling compound according to the manufacturer's instructions. Before beginning, check that the floor temperature meets the manufacturer's specified requirements. Always follow the manufacturer's instructions regarding compound thickness, mixture, drying time, and temperature limits
- Apply the moisture barrier system to the fully dried levelling compound surfaces according to the supplier's instructions. Use only products that are recommended by the supplier for the specific moisture barrier system being installed.

**NOTE! Drying requirements**

Ensure that the levelling compound has fully dried before applying the waterproofing system, as these layers will be enclosed between two relatively moisture-resistant layers.



Installation, primer and adhesive in wet rooms – Table 2.

This table lists the laying methods and products that have been tested and are recommended for the Scandinavian markets. Always follow the instructions provided by your local supplier for correct installation. For additional guidance or questions, contact your local supplier directly.

Supplier	Installing LK CombiBoard EPS boards	Primer on the laminated heat distribution layer (aluminium)	Levelling on boards
Alfix A/S	Alfix Ready Flex	Alfix UniversalPrimer	Alfix PlaneMix 60, min. 12 mm.
Bostik AB	On chipboard or concrete below 85 % RH: STIX A500 Combi, Bostik STIX A511 Combi Air or STIX A800 Premium. Concrete sub-floors: Bostik 8070 Light LT (double glued) or Bostik 8040 Flow LT	Bostik GRIP A936 Xpress	SL C500 Fiber Quick or SL C700 Fiber Quick+. min. 12 mm
Kiilto AB	Kiilto Floorfix DF together with Kiilto Pro Fixbinder.	Kiilto Fix Pro Primer	Kiilto Floor Heat DF, Kiilto Pro Plan Vario, Kiilto Pro Plan Craft. Min 12 mm.
LIP	Mount the boards using LIP XXL Large Format Adhesive.	LIP Supergrund	Apply LIP Reinforcement Mesh over the entire surface, extending to the floor drain. The minimum leveling compound thickness on the panel must be 12 mm, continuing all the way to the drain, using LIP 210, 220, or 226 Self-Leveling Compound.
PCI	Mount the boards with PCI Flexmortar S1 Flott.	Prime with PCI Gisogrund 303. Putty (min. 12mm at floor drain) with PCI Periplan CF35 / PCI FT Plan Pro, use ROT net or equivalent, use PCI Pectape Silent (Edge tape).	Tiling can be done with PCI Flexmörtel S1 Flott, PCI Flexmörtel S1, PCI FT Extra, PCI Nanolight, PCI Nanolight Tiling with natural stone is carried out with PCI Carraflex.
Mapei AB	Ultralite S2 Flex Zero or Ultralite S2 Flex Quick Zero	Primer EcoPrim T or EcoPrim Grip Plus	Uniplan Eco, min 12 mm.
SCHÖNOX	Installation in wet rooms: Mount the boards with Schönnox FS.	Installation in wet rooms: Excellent with Schönnox SHP. Putty with Schönnox TX and use Schönnox PZG (reinforcement mesh)) with Schönnox RS 50 (Edge strip). my. 12mm locally at the well, max. floor area 10 square meters.	Installation in wet rooms: Tiling can be done with Schönnox Q6, Q6W, Q8, Q9W, Q12, TT S8 and TT S8 Rapid.
SikaCeram	Mount the boards with Casco Husfix Rapid.	Prime with SikaFloor-02 Primer. Putty with SikaCeram-450 Thermo Level and with a root net. my. 20mm.	Tiling can be done with SikaCeram- 260 StarFlex and 275 Marble & Stone.

OTHER TYPES OF FLOORING MATERIAL

Many other types of floor coverings than ceramic tiles can be used, such as resilient or various wood products. See separate heading for each flooring material.

Construction principle

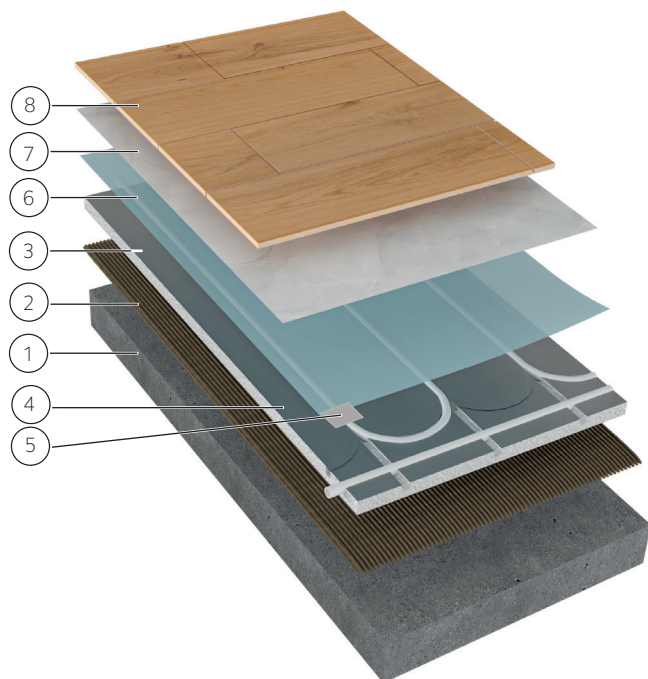

1. Concrete.
2. Glue recommended by the supplier.
3. LK CombiBoard EPS.
4. LK Underfloor Heating Pipe.
5. LK Aluminium Tape.
6. Vapour barrier.
7. Paper felt.
8. Wooden floor.

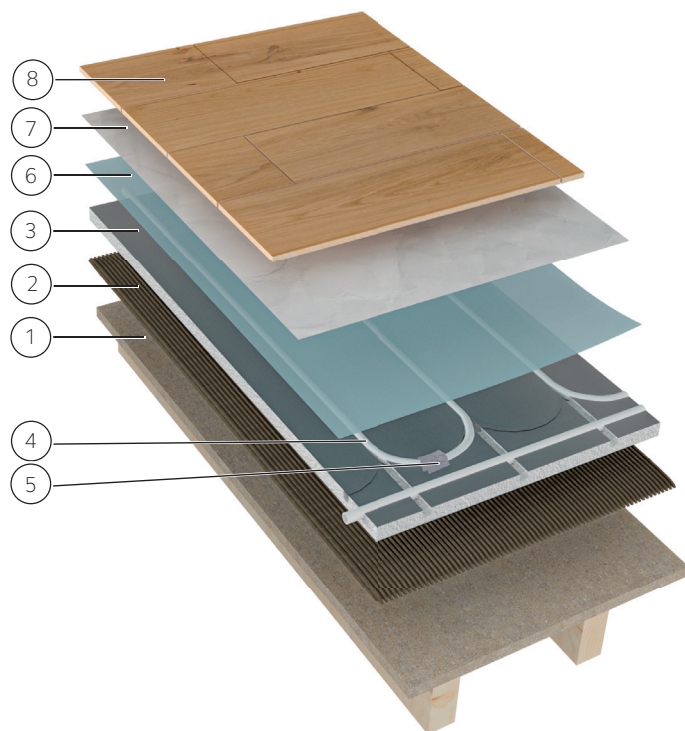

1. Wooden joists with chipboard.
2. Screw or glue recommended by the supplier.
3. LK CombiBoard EPS.
4. LK Underfloor Heating Pipe.
5. LK Aluminium Tape.
6. Vapour barrier.
7. Paper felt.
8. Wooden floor.



Various types of wooden flooring with floating installation

ATTENTION! Expansion gaps

Follow the flooring supplier's instructions. When laying wood products onto underfloor heating systems, **it is especially important to follow the instructions in terms of expansion gaps.**



ATTENTION! Industry guidelines

For guidance on installing wooden flooring over underfloor heating systems, always follow applicable local or national standards. As a reference, industry guidelines from the Swedish Flooring Trade Association (GBR) are available in the handbook "Trägolv på golvvärme" (Wooden Flooring on Underfloor Heating Systems), Edition 3: 2022. The handbook can be downloaded from www.golvbranschen.se.

ATTENTION! Flooring thicknesses above 25 mm

The respective flooring manufacturer's instructions, as well as GBR's guidelines for wooden floors on underfloor heating, must be followed. Always consult LK for floor thicknesses exceeding 25 mm. Increased thickness may reduce the efficiency of heat transfer and delay the system's thermal response.

Requirements

- An intermediate layer is required when laying vinyl flooring.
- The floating floor should be installed room by room and must be able to move freely in all directions. Therefore, an expansion gap must be maintained between the floor and the walls around the entire perimeter of the room.
- The same applies to all fixed or heavy installations, such as kitchen cabinets, kitchen islands, staircases, pillars, thresholds, pipes, cooktop connections, stone flooring, and similar elements. This expansion gap is typically concealed using skirting boards or mouldings.
- If the floating floor is to be installed beneath kitchen units, the floor must be divided and laid as a separate section, with expansion space provided between it and the rest of the flooring. Alternatively, holes can be drilled through the floating floor and the underfloor panel to allow support legs to rest directly on the subfloor—remember to leave an expansion gap around each leg.
- Underfloor heating means that the wood dries out more during the period of the year when the heating is on compared to if underfloor heating has not been installed.
- The underfloor heating will cause slightly larger gaps between the floorboards during the driest winter months.
- As a general rule, a vapour barrier (e.g. age-resistant expanded 0.2 mm polythene film) should be laid over the underfloor heating system. The add a layer of paper felt, age-resistant expanded polyethylene foam with closed cells (e.g. Airolen®), or cork underlay.
- The underfloor heating is first covered with a vapour barrier in accordance with the flooring manufacturer's instructions, followed by grey paper felt or cellular foam. The respective flooring manufacturer's instructions, as well as the guidelines from GBR for wooden floors over underfloor heating, must be followed.

Solid wood (floorboards or parquet blocks)

ATTENTION!

Follow the flooring supplier's instructions. When laying wood products onto underfloor heating systems, it is especially important to follow the instructions in terms of **expansion gaps**.



The wooden floorboards **must be laid at right angles** to the main direction of the pipe loop.

The **thermal conductivity** of the wood is almost twice as great in the direction of the grain compared to the radial direction. Using the natural properties of the wood in this way ensures a more even surface temperature.

Total thermal resistance of the construction

The total height of the floor structure should not exceed 25 mm. If it exceeds 25 mm, contact LK for guidance.

- Solid wood flooring is installed by nailing, screwing, or gluing it down onto plywood or chipboard laid as a floating subfloor. For glued flooring, the method using a self-levelling compound is a good option as an intermediate layer due to its lower thermal resistance.
- A method, suitable for floorboards that can be screwed down, involves fixing wooden battens between each LK CombiBoard EPS board. The battens must be the same height as the LK CombiBoard EPS board, have a minimum width of 40 mm, and be permanently fixed to the subfloor. The spacing between battens must be less than the maximum screw distance specified by the floorboard manufacturer. No intermediate layer is required in this solution, as the floorboards can be mounted directly onto the battens. The underfloor heating is first covered with a vapour barrier in accordance with the flooring manufacturer's instructions, followed by grey paper felt or cellular foam. *The respective flooring manufacturer's instructions, as well as the guidelines from GBR for wooden floors over underfloor heating, must be followed.*

Engineered wood flooring (3-layer parquet)



ATTENTION!

Follow the flooring supplier's instructions. When laying wood products onto underfloor heating systems, it is especially important to follow the instructions in terms of expansion gaps.

- Normally, LK CombiBoard EPS should be covered with a vapour barrier, followed by paper felt. The engineered wood flooring is then laid floating on top of the paper felt. *The respective flooring manufacturer's instructions, as well as the guidelines from GBR for wooden floors over underfloor heating, must be followed.*

Laminate and click-lock flooring

NOTE!

Laminate flooring thicker than 8 mm

8 mm is the minimum thickness for laminate flooring when no intermediate board is required. The laminate flooring can be installed as a floating floor on top of LK CombiBoard EPS with the necessary intermediate layer. The intermediate layer must function as both a vapour barrier and a slip layer, if these are not already included in the construction. A common solution is a 0.2 mm PE film with a minimum 200 mm overlap, with grey paper felt placed on top. Alternative intermediate layers that serve the same function may also be used.

Laminate flooring thinner than 8 mm

For structural reasons, a floating intermediate board is recommended under laminate flooring thinner than 8 mm – for example, 6 or 8 mm MDF boards with tongue and groove, glued together. Check whether the laminate flooring includes a vapour barrier or slip layer; if not, a vapour barrier such as 0.2 mm PE film must be installed under the board, with grey paper felt placed on top. Organic materials such as wood must not be placed between two impermeable layers.



Laminate flooring in decorative patterns

Smaller laminate planks installed in decorative patterns, such as herringbone or chevron, always require an intermediate layer on top of the LK CombiBoard EPS board before the laminate flooring is laid. In addition, a vapour barrier and slip layer are required.

Movement joints

When installing wood flooring over underfloor heating systems, it is especially important to follow the instructions regarding expansion joints. Refer to the laminate/click flooring manufacturer's guidelines.



- The most common installation method is free floating with a suitable underlay. Some laminate floors feature an integrated sliding layer — such as cork, paper felt, or cellfoam — which can be complemented with a vapour barrier if required. Paper felt is preferred due to its low thermal resistance, ensuring efficient heat transfer. *The respective flooring manufacturer's instructions, as well as the guidelines from GBR for wooden floors over underfloor heating, must be followed.*

Soft or glued flooring with intermediate layer

- Soft, flexible, and thin floor coverings — such as vinyl, wall-to-wall carpet, linoleum, cork or rubber — must not be installed directly on LK CombiBoard EPS board. These materials need an intermediate layer that provides a flat, stable, and load-bearing surface to prevent movement, damage, or uneven heating.
- This also applies to glued wooden flooring and poured floor coverings as polyurethane (PU resin), terazzo, micro-cement and polished cement. Without a proper sublayer, the adhesive bond may deteriorate, and the flooring may warp or crack over time due to thermal fluctuations, moisture expansion, or uneven support.

Approved Installation Methods

Semi-Floating Board System

- Install a semi-floating layer using rigid boards or sheets (e.g., MDF, chipboard, fiberboard or plywood). Lay them loosely over the heating panels, ensuring an appropriate expansion gap around the perimeter of the room. If wooden boards are used, a vapour barrier (e.g. 0.2 mm polythene) and paper felt should be laid over the underfloor heating system.
- Make sure all joints are flush and level — any gaps or unevenness will transfer through to the final floor surface.
- The intermediate layer should be thin and have good thermal conductivity to effectively transfer heat upward.
- If using a floating chipboard subfloor, the minimum thickness should be 10 mm or 16 mm, depending on the load category or building type. Contact a structural engineer or other expert in case of uncertainty.

Fiber-Reinforced Screed

- Apply a thin layer (approx. 10 mm) fiber-reinforced levelling compound to create a smooth, durable base.
- This method is ideal when a fully bonded surface is required before installing soft or glued flooring.
- The underfloor heating system must be primed to ensure proper adhesion between the levelling compound and the laminated heat distribution layer (aluminium). Select the appropriate primer and levelling compound from the relevant table.



TIP! When an intermediate layer is required

Always verify product compatibility with underfloor heating according to the manufacturer's guidelines. Ensure that levelling compounds are fully cured before proceeding with flooring installation. Incorporate expansion joints where necessary to manage thermal and moisture-related movement. Lay paper felt as a protective underlayer before installing any intermediate boards or sheet materials.

Vinyl and Resilient Flooring Types

NOTE! When an intermediate layer is required

An intermediate layer is required when laying vinyl flooring and LVT (Luxury Vinyl Tiles). Paper felt must be laid before the intermediate layer is laid.



If the flooring is flexible and pliable, it should be handled as “vinyl flooring”, and LK recommends laying a hard board (intermediate layer) on top of the LK CombiBoard EPS boards.

LVT or LVP with an MDF or HDF backing

If the vinyl flooring is a thicker variant with an MDF or HDF backing, it may be possible to install it floating, similarly, to laminate flooring.

Before laying the flooring, always check the floor supplier's recommendations.

There are several types of vinyl flooring that need an intermediate layer, including:

- LVT (Luxury Vinyl Tiles).
- LVP (Luxury Vinyl Planks) — also known as PVC flooring.
- These products come in manageable tile or plank formats and can be installed either as floating floors (without adhesive) or fully bonded using a suitable adhesive, depending on the application and manufacturer recommendations.
- In contrast, sheet-based flooring materials — such as plastic, vinyl, and linoleum — are typically supplied in rolls and must be adhered directly to the subfloor using an appropriate adhesive to ensure proper bonding and performance.
- It is important that the intermediate layer is thin and has good thermal conductivity so that it can transfer the heat upwards effectively. For instance choose 6 mm “Funktion Mellangolv” from Moelven, 7 mm Forbo Quickfit or equivalent.
- If you choose a floating chipboard sub-floor, the minimum thickness must be 10 mm or 16 mm, depending on the load category /building type. In public buildings, it may be necessary to use a stronger/thicker intermediate layer due to the higher load. In public buildings, there may be a need to use a stronger/thicker one. Contact a structural engineer or other expert in case of uncertainty.
- The underfloor heating system can also be thinly spackled with fibre-reinforced floor spackle (approx. 10 mm) before the top flooring is laid.
- If the top flooring is flexible and pliable, it should be treated as a “vinyl floor covering,” and LK recommends installing a hardboard (intermediate layer) on top of the LK CombiBoard EPS boards.
- If the vinyl flooring is a thicker type with an MDF/HDF backing, it may be possible to install it as a floating floor in the same way as laminate flooring
- The underfloor heating system must be primed to better enable the spackle to adhere to the laminated heat distribution layer (aluminium). Select the primer and spackle as per *“Installation, primer and adhesive in dry rooms – Table 1.” on page 12.*



Wall-to-Wall Carpet Floor Coverings

- Carpets and rugs can be used with underfloor heating systems. However, it's important to note that these materials typically act as insulators, which may reduce the efficiency of heat transfer. A floor covering with high insulating properties can hinder the heat from rising into the room, affecting both comfort and system performance.
- To ensure optimal results, always consult the supplier to confirm that the carpet or rug is suitable for use with underfloor heating. If you have any questions regarding compatibility, feel free to contact us. In most cases, carpets can be installed using adhesive or double-sided tape applied to the intermediate layer.

**NOTE! Planning underfloor heating with carpet grippers**

If the carpet is to be installed using grippers, begin by fixing a wooden batten around the perimeter of the room, including doorways, before laying out the LK CombiBoard EPS board. The batten should be the same height as the LK CombiBoard EPS board to ensure a level surface. This provides a secure base for attaching both door thresholds and carpet grippers.

ENVIRONMENT/RECYCLING

Once the LK CombiBoard EPS boards reach the end of their life, they should be sorted for energy recycling and taken to a recycling centre.

MISCELLANEOUS

The LK CombiBoard EPS boards may contain traces of black EPS beads. **Protection during transport:** During transport and storage, the discs must be protected against dirt and moisture. The boards must be transported and stored on a flat surface. LK CombiBoard EPS must be stored indoors.

TECHNICAL DATA

Essential properties	Performance	EN-Standard
Thermal conductivity	$\lambda_D = 0,033 \text{ W/mK}$	EN 12667:2001
Thermal resistance	$R \text{ (m}^2\cdot\text{K/W)}$	EN 1264-3 2021
LK CombiBoard 14	0,397	
LK CombiBoard 18	0,507	
LK CombiBoard 30	0,870	
LK CombiBoard 50	1,476	
LK CombiBoard 70	2,082	
Compressive stress at 10% deformation	CS(10) = 300 kPa	EN ISO 29469:2022
Bending strength	450 kPa	Cf. annex C*
Shear strength	225 kPa	Cf. annex F.3*
Shear strength, long term (2 %)	CC = 90 kPa	Cf. annex F.2*
Water absorption long term (water absorption at full immersion)	WL(T) 5	EN/ISO 16535:2019
Watervapor transmission μ	40 - 100	Cf. annex F.4*
Watervapor permeability $\delta \text{ mg/(Pa.h.m)}$	0,006 - 0,015	Cf. annex F.4*
Fire class (Reaction to fire)	NPD (Euroclass F)	
Continuous glowing combustion	NPD	
Durability of thermal conductivity against heat, weathering and ageing/degradation	No change over time and NPD (c)	
Durability of compressive strength against ageing/degradation – Freeze-thaw resistance	NPD	
Durability of compressive strength, ageing and degradation – long term thickness reduction	NPD	
Tensile strength	NPD	
Deformation under specific load	NPD	
Acoustic absorption indexes	See the Impact Sound Improvement table	
Release of dangerous substances	NPD (a)	

*See SS/EN 13163:2012+A2:2016 for reference.

NPD = Non Proven Data

Compare = Cf.

(a) Test method is not available.

(c) The fire performance of EPS does not deteriorate with time.

Impact sound improvement	Flooring material	Weighted impact sound improvement $\Delta L_W \text{ (dB)}$	Spectrum adjustment term for impact sound improvement $CIA \text{ (dB)}$
LK CombiBoard 14	Parquet flooring 14 mm	18	-11
LK CombiBoard 18	Parquet flooring 14 mm	19	-11
LK CombiBoard 30	Parquet flooring 14 mm	19	-11
LK CombiBoard 14	Ceramic tiles, dry area	16	-10
LK CombiBoard 18	Ceramic tiles, dry area	16	-10
LK CombiBoard 30	Ceramic tiles, dry area	15	-11
LK CombiBoard 14	Ceramic tiles, wet area	21	-12
LK CombiBoard 18	Ceramic tiles, wet area	20	-11
LK CombiBoard 30	Ceramic tiles, wet area	17	-10



DIMENSION DRAWINGS

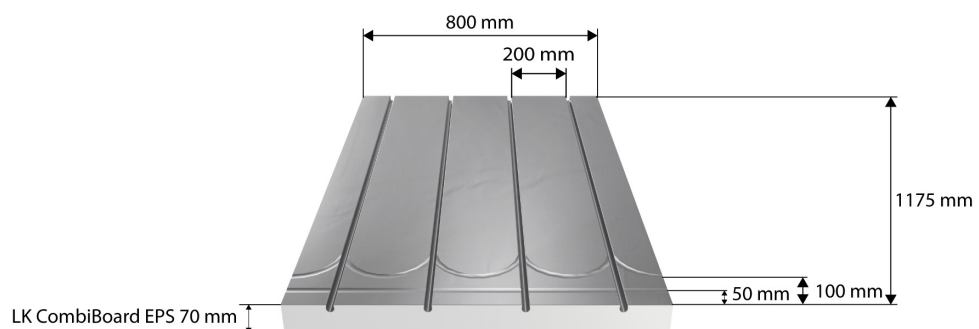
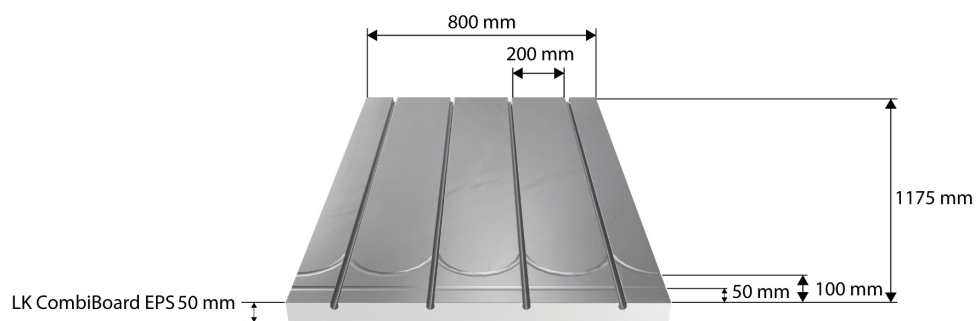
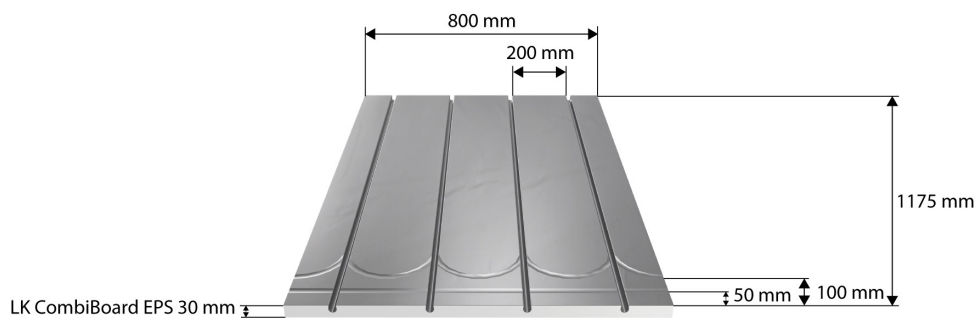
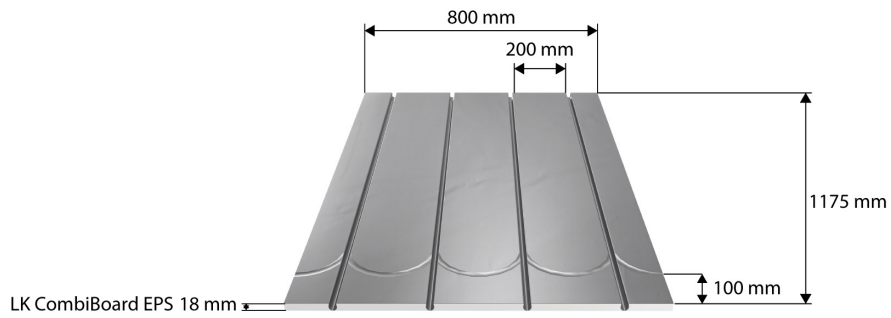
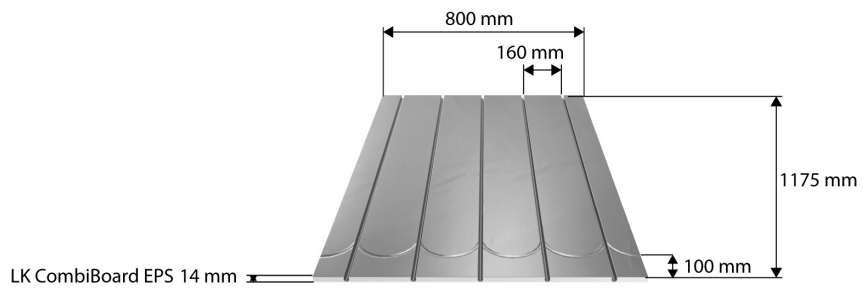

LK CombiBoard EPS 30/50/70 - c/c 50 (Feed), c/c 100 mm.

LK CombiBoard EPS 30 100 cc

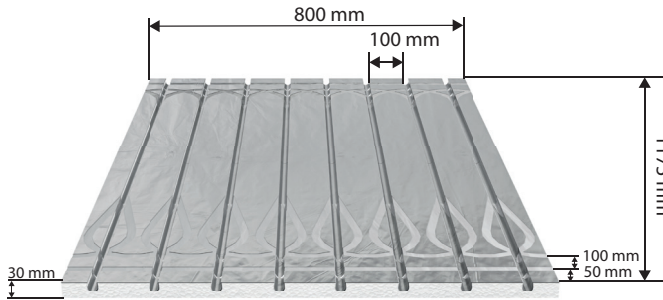

LK CombiBoard EPS 30 Feed 50 cc

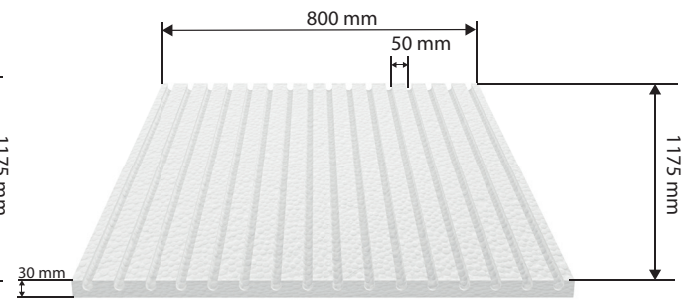

LK CombiBoard EPS 50 100 cc

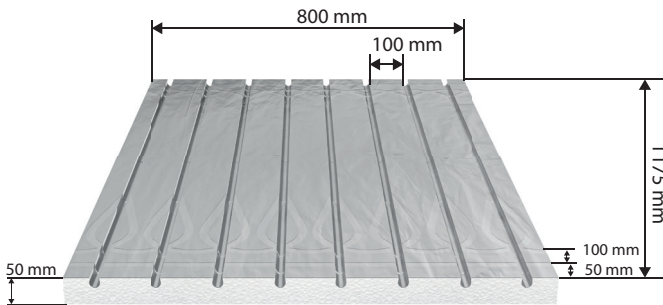

LK CombiBoard EPS 50 Feed 50 cc

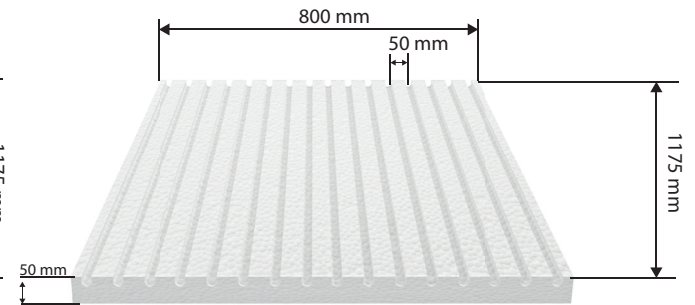

LK CombiBoard EPS 70 100 cc

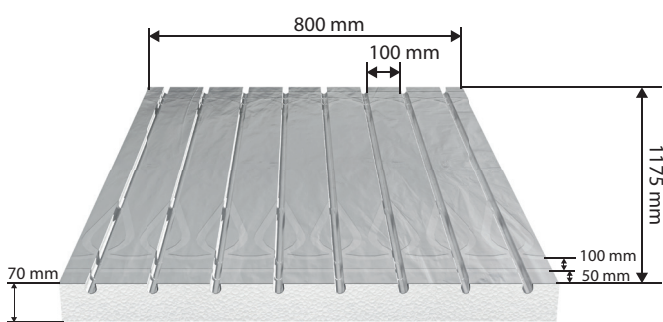

LK CombiBoard EPS 70 Feed 50 cc

